

**NOX  
CYC  
LES**  
NOXCYCLES.COM



*EVOLUTION* 1.0

**HeLIUM**

SERIES

**N**  
**MORE**  
**EXCUSES.**

**NOX**  
**CYC**  
**LES**

NOXCYCLES.COM

PERFECT E-BIKE.  
PERFECT DAY.

We at Nox Cycles regard ourselves as a manufacturer of high-tech e-bikes. We are driven by a passion to build the best electric mountain bikes around. Our guiding principle is to offer every customer top quality and individuality.

NOX HeLIUM e-mountain bikes take freedom and adventure to a whole new level.

# EVERY REVOLUTION NEEDS ITS **EVOLUTION**



## THE BEST OF 2 WORLDS

In the form of the **HeLIUM** series, we are presenting our new electric mountain bike range that is aimed above all at sporty-minded customers yet still conveys the natural, dynamic ride-feeling of an unmotorised bicycle. The unique, slender design and light weight enable trail adventures previously only conceivable with a non-motorised mountain bike. Coupled with the serious benefit of motor assistance, however, you'll experience a tailwind riding uphill and feel as light as helium.

## 2 IN 1 - THE NEW FLeXIBILITY

Not only does the Fazua evation drive system provide the e-bike with a sporty character, it is also integrated elegantly and inconspicuously into the frame – with previously unparalleled flexibility: In a matter of seconds, you can convert your e-bike into a normal bike and enjoy unlimited freedom **WITHOUT A MOTOR** as well.

Both colours  available for

Enduro **7.1** 29" / 27.5"+ | 180mm

&

All Mtn **5.9** 29" / 27.5"+ | 150/160mm

# EXPERT

## SETUP

The EXPERT models have been conceived as athletic all-rounders. E-bike-specific components throughout and a carbon frame are but a few of the highlights that provide for pure cycling pleasure – from your home trail through to extended tours in challenging terrain. Here you'll find a dynamic and more than reliable partner.

# PRO

## SETUP

The PRO model range makes a premium yet mysterious impression. Designed for continuous operation in the toughest conditions, the emphasis here is on performance and weight-optimisation. Alongside a carbon frame, the models are equipped uncompromisingly with premium components and many other highlights for a top-class cycling experience.



WHEN THINGS GET TOO HEAVY,  
JUST CALL ME HeLIUM,  
THE LIGHTEST KNOWN GAS  
TO MAN.

- JIMI HENDRIX



CHANGING **E** BIKING AS YOU KNOW IT.

# EVOLUTION 1.0

## Q&A

With the NOX HeLIUM line, we are entering an entirely new electric mountain bike market and appealing to all bikers with sporting ambitions, who want to be leading the way on all trails with a single, lightweight, agile bike both with and without electric drive:

**WHAT DO YOU DO IF YOU'RE OUT WITH YOUR E-BIKING FRIENDS ON THE REGULAR LOCAL EVENING RIDE AND REALISE THAT YOU ALSO NEED ELECTRIC ASSISTANCE TO KEEP UP WITH THEM NOW?**

Click your Fazua evation system into the bike and, with a bike weight of 17.9 kg – 18.9 kg (depending on equipment), you'll not only be holding your own but also taking the lead. Even if your friends have a little more power, you benefit from the absolute HeLIUM weight advantage both uphill, and most of all, in technical terrain going downhill.

**ARE YOU PLANNING A LONGER, HIGHLY CHALLENGING TOUR FOR THE WEEKEND?**

Then go for it! A 252 Wh spare battery is only the size of a 0.5 l water bottle and weighs just 1.38 kg. With a total of 504 Wh (or 756 Wh with two spare batteries, etc.), the extremely economical Fazua evation system and the HeLIUM weight of your bike, you'll have no need to worry about range. The same goes for sections where most have to carry or push their bike – when your friends are already shoving their heavyweights, you still have enough power in your battery and/or legs – and you can lift your bike easily over obstacles.



NOX

HeLIUM  
SERIES

LIGHT

NATURAL

DYNAMIC

ATHLETIC

FLEXIBLE

AESTHETIC

INTERACTIVE

**BUT WOULD YOU SOMETIMES LIKE TO REALLY BURN OFF ENERGY AND PEDAL UP THOSE HILLS ON A HELIUM BIKE WEIGHING 13-14 KG AND ENJOY UNLIMITED FREEDOM WITHOUT A MOTOR AS WELL? OR TAKE A TRIP TO A BIKE PARK EQUIPPED WITH SHUTTLE OR LIFT?**

No problem: Simply remove the Fazua evation drive and battery completely from the bike, mount the cover, and the wild ride can begin. Your added benefit: The hollow area in the down-tube cover can also be used as a practical stowage space for repair kit, tools and provisions.

NOX HeLIUM: THE **EVOLUTION** HAS BEGUN.



# TECH & DESIGN



## CONNECTIVITY

With the Fazua app you can connect your bike at any time to your smartphone to collect and analyse data and, with that, find out more about your training and your bike

## SHORT- AND LONG-HAUL

If you plan to go on longer tours, you can extend your range at any time by using one or more light & compact replaceable batteries

**BATTERY** 250Wh, 36V, 1.36kg

## FLEXIBILITY

In a matter of seconds, you can convert your e-bike into a normal bike. Simply remove the drive unit and battery and replace them with the down-tube cover – done!

## LIGHT AND COMPACT

The Fazua evation drive system is the lightest and most compact drive system in its class. It provides for a dynamic yet natural cycling experience, generates next to no noise and lets you pedal with no resistance at all at speeds above 25 km/h.

## BOTTOM BRACKET TRANSMISSION

60Nm, 1.3kg

## MOTOR UNIT 250W, 1.9kg

## WEIGHTLESS

Exceptionally low overall weight thanks to a carbon frame, the evation drive system and high-quality components (from 17.9kg)

## EQUIPMENT OPTIMISED FOR E-BIKES

Uncompromising equipment to meet the demands of challenging terrain

## FLEXIBLE TYRE SELECTION

Tyre width up to 2.8" (for 27.5") with Boost Standard  
Wheel size 27.5" / 29" by flip chip

## INTEGRATED AND ELEGANT

A new dimension in e-bike aesthetics based on innovative technology and a slender frame geometry coupled with the unmistakable NOX design language



## NATURAL AND ATHLETIC

The riding pleasure and dynamics of a bike without a motor are preserved thanks to a modern geometry (long wheelbase, flat steering angle, short chain stays) and low overall system weight

# DRIVE UNIT



## THE LIGHTEST AND MOST COMPACT DRIVE SYSTEM IN ITS CLASS

In the form of the evation drive, German motor manufacturer Fazua supplies an electric drive system that is aimed above all at sporty-minded bikers yet still conveys the natural ride-feeling of an unmotorised bicycle. An innovative approach that coincides perfectly with the vision and passion of NOX: to continuously review electric mountain bikes and raise them to a new level.

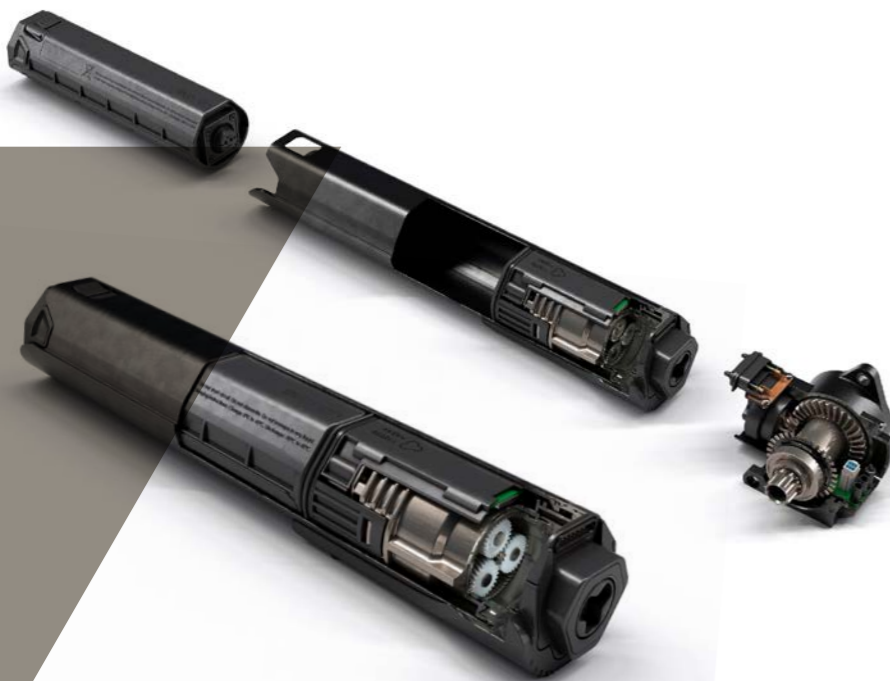

### WEIGHT

Weighing in at only 4.6 kg, the evation is the lightest and most compact drive system in its class. The riding pleasure and dynamics of a bike without a motor are preserved thanks to the low overall system weight.

### DESIGN

Thanks to its innovative design and underlying technology, the drive system can be integrated elegantly into the down tube, so the bike does not look like an e-bike at all at first glance.

### ASSISTANCE

The drive system adapts itself entirely to its rider thanks to torque measurement on both sides and cadence measurement in the bottom bracket. If you ride sportily and apply plenty of power to the cranks, you'll also be correspondingly well supported.

### PEDAL RESISTANCE

The motor cuts out automatically at over 25 km/h. The integrated freewheel is designed so you can achieve top speeds by yourself, without any unnatural pedal resistance. The system can also be deactivated completely at the push of a button, allowing the bike to be used conventionally without any pedal resistance.

### 2 IN 1

The drive unit and battery can be removed together in one simple operation and then replaced with the down-tube cover available as an option. This allows you to convert your e-bike into a normal bike in a matter of seconds. You can also use the hollow area as a practical stowage space for repair kit, tools and provisions.

### REPLACEABLE BATTERY

The battery has deliberately been kept small and light: All you need to do for a particularly long ride is pack a spare battery (1.38kg), which gives you 252 Wh extra power in only the size of a 0.5 l water bottle.

### DATA

Nowadays, most sporty-minded cyclists collect and analyse their data. The Fazua app is compatible with all e-bikes equipped with a Fazua evation drive system and supplies you with immediate access to much more data, so you can find out more about your training and your bike.

- GPS navigation and positioning
- Tachometer
- Technical overview, battery level
- Support, direct access to Fazua Service
- Share rides with friends
- Summary and detailed analysis of the collected ride data

MOTOR UNIT  
**REMOVABLE**

POWER  
**250 W**  
PEAK 400 W

**BOTTOM BRACKET**

TORQUE  
**60 NM**

WEIGHT  
**1.31 KG**

**DRIVEPACK**

WEIGHT  
**1.92 KG**

**BATTERY**

BATTERY PACK  
REPLACEABLE  
**LI-ION**

ENERGY CONTENT  
**252 WH**

VOLTAGE  
**36 V**

WEIGHT  
**1.38 KG**

**REMOTE**

SUPPORT  
MODES

**3**

BLUETOOTH  
**READY**

# 5.9

## ALL-MOUNTAIN 5.9 ATHLETIC, DYNAMIC, VERSATILE

Looking for an electric All-Mountain bike that gives you the feeling of a natural ride? With an extra portion of power in your legs going uphill and the performance of a "normal" All-Mountain bike going downhill? A bike that you can convert in a flash, opening the way to unlimited freedom for rides without a motor as well?

If your answer to these questions is YES, then we have a real all-rounder for you: the NOX HeLIUM All-MOUNTAIN 5.9: A modern and attractive e-MTB that can accompany you on all your rides, be it your regular tour or an alpine crossing.

### DETAILS

- Carbon frame
- Race-tested geometry
- Fazua evation 1.0 drive system (250W, 36V, 60Nm, 250Wh)
- 2-in-1 (including down-tube cover)
- Suspension travel 160/150mm
- Wheel size 27.5" / 29" by flip chip
- All-Mountain-specific components
- Bluetooth-enabled remote
- Mount for kick stand

PHANTOM

GRANIT



# 5.9

ALL-MOUNTAIN

PRO PHANTOM



EXPERT GRANIT



## 5.9 All-Mountain **PRO**

### DRIVE

<b>CRANKSET</b>	SRAM X1 E-Crank, 165mm, 34T
<b>REAR DERAILLEUR</b>	SRAM XX Eagle 12x
<b>SHIFTER</b>	SRAM XX Eagle 12x
<b>CASSETTE</b>	SRAM PG 1230, 11-50T
<b>MOTOR</b>	FAZUA drive pack
<b>BATTERY*</b>	FAZUA battery 7000 evation 1.0 36V-7Ah-252Wh
<b>CHARGER</b>	FAZUA charger
<b>DISPLAY</b>	FAZUA Evation 1.0 Remote CD22, CL1414

### EQUIPMENT

<b>FRAME</b>	NOX Helium Carbon frame
<b>FRAME SIZES</b>	M, L
<b>FORK</b>	FOX 36 Factory RC2, 29"/27,5"+, 160mm
<b>REAR SHOCK</b>	FOX Float X2 Factory 230x60mm
<b>STEM</b>	RENTHAL Apex 35
<b>HANDLEBAR</b>	RENTHAL Fatbar Lite 35 Carbon
<b>GRIPS</b>	ODI

<b>SEAT POST</b>	FOX Transfer Factory Post
<b>SADDLE</b>	PROLOGO Proxim W650 Microfiber P1 +Grip
<b>WHEELSET**</b>	STAN'S Notubes Arch CB7, 29"
<b>TYRES**</b>	CONTINENTAL Der Baron Project 29x2,4" ProTction Apex
<b>BRAKES</b>	MAGURA MT7 HC

€ 7.999,-

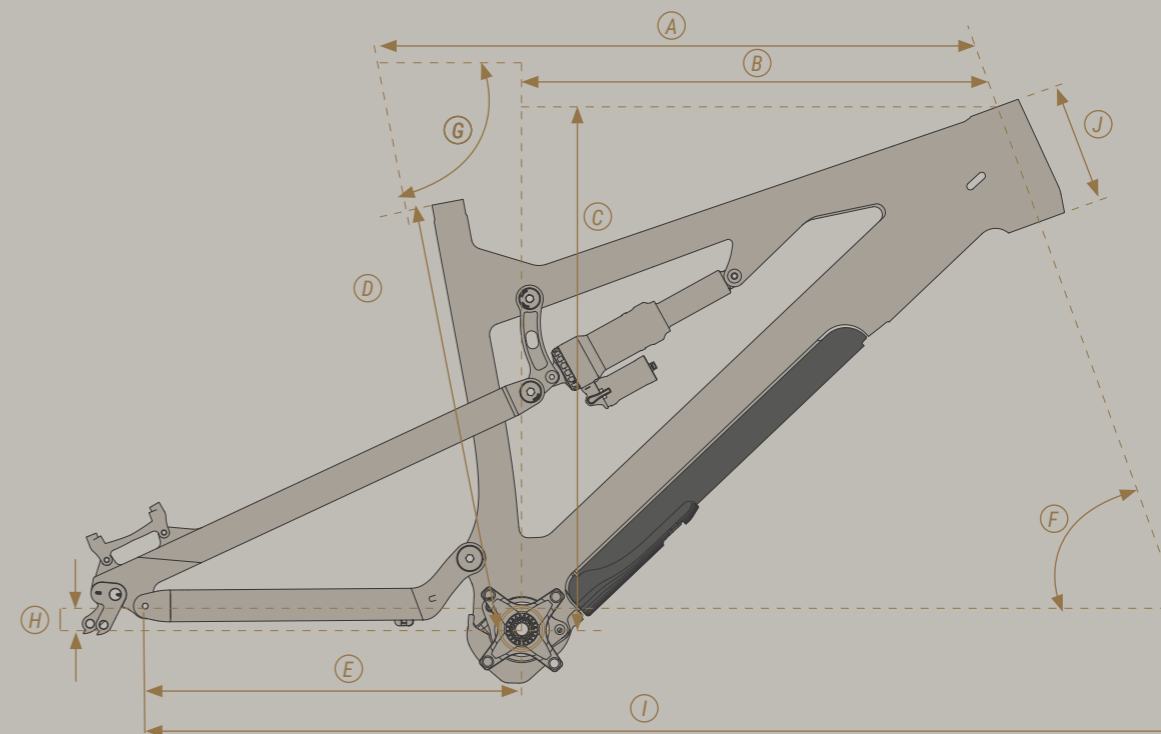
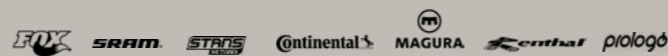

## 5.9 All-Mountain **EXPERT**

### DRIVE

<b>CRANKSET</b>	SRAM EX1 E-Crank, 165mm, 34T
<b>REAR DERAILLEUR</b>	SRAM GX Eagle 12x
<b>SHIFTER</b>	SRAM GX Eagle 12x
<b>CASSETTE</b>	SRAM PG 1230, 11-50T
<b>MOTOR</b>	FAZUA drive pack
<b>BATTERY*</b>	FAZUA battery 7000 evation 1.0 36V-7Ah-252Wh
<b>CHARGER</b>	FAZUA charger
<b>DISPLAY</b>	FAZUA Evation 1.0 Remote CD22, CL1414

### EQUIPMENT

<b>FRAME</b>	NOX Helium Carbon frame
<b>FRAME SIZES</b>	M, L
<b>FORK</b>	ROCK SHOX Pike Select, 29"/27,5"+, 150mm
<b>REAR SHOCK</b>	ROCK SHOX Super Deluxe Select R 230x60mm
<b>STEM</b>	NOX Components 35 Stem
<b>HANDLEBAR</b>	NOX Components 35 Risebar
<b>GRIPS</b>	ODI

<b>SEAT POST</b>	ROCKSHOX Reverb Stealth
<b>SADDLE</b>	PROLOGO Proxim W450
<b>WHEELSET**</b>	DT SWISS H1900 Spline, 29"
<b>TYRES**</b>	CONTINENTAL Trail King 29x2,4" Shieldwall
<b>BRAKES</b>	MAGURA MT5 HC

€ 5.999,-



		M		L	
		27.5"	29"	27.5"	29"
<b>A</b>	Top tube (horizontal)	610mm	610mm	635mm	635mm
<b>B</b>	Reach	446mm	446mm	470mm	470mm
<b>C</b>	Stack	613mm	613mm	617mm	617mm
<b>D</b>	Seat tube	433mm	433mm	478mm	478mm
<b>E</b>	Chain stay	453mm	468mm	453mm	453mm
<b>F</b>	Steering angle	65°	65°	65°	65°
<b>G</b>	Seat angle	74.5°	74.5°	74.5°	74.5°
<b>H</b>	BB drop	n.s.	n.s.	n.s.	n.s.
<b>I</b>	Wheelbase	1233mm	1249mm	1259mm	1259mm
<b>J</b>	Head tube	135mm	135mm	135mm	135mm

Equipment and prices subject to change

Battery Cover for extracted drive unit included

\* Additional battery FAZUA 7000 evation 252Wh: 299€ SRP  
Only valid in connection with bike purchase

\*\* Additional tyre/wheel sizes also available



# 7.1

## ENDURO 7.1 QUICK, AGILE, LIVELY.

Looking for downhill fun previously unparalleled on an e-bike and an extra portion of power in your legs going uphill? A bike that you can convert in a flash, opening the way to unlimited freedom for days at the bike park and shuttle trips without a motor as well?

If your answer to these questions is YES, then we have the perfect bike for you: the NOX HeLIUM ENDURO 7.1. A stamina-saving uphill experience for as many downhill kilometres as possible. An e-MTB for extreme, long rides on single trails and over rough terrain or in bike parks – with and without electric power.

### DETAILS

- Carbon frame
- Race-tested geometry
- Fazua evation 1.0 drive system (250W, 36V, 60Nm, 250Wh)
- 2-in-1 (including down-tube cover)
- Suspension travel 180mm
- Wheel size 27.5" (Pro) // 27.5" / 29" (Expert) by flip chip
- Enduro-specific components
- Bluetooth-enabled remote

PHANTOM

GRANIT

# 7.1

ENDURO



# PRO PHANTOM



# EXPERT GRANIT

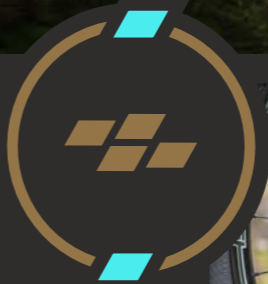

## 7.1 ENDURO PRO

### DRIVE

<b>CRANKSET</b>	SRAM X1 E-Crank, 165mm, 34T
<b>REAR DERAILLEUR</b>	SRAM X0 Eagle 12x
<b>SHIFTER</b>	SRAM X0 Eagle 12x
<b>CASSETTE</b>	SRAM PG 1230, 11-50T
<b>MOTOR</b>	FAZUA drive pack
<b>BATTERY*</b>	FAZUA battery 7000 evation 1.0 36V-7Ah-252Wh
<b>CHARGER</b>	FAZUA charger
<b>DISPLAY</b>	FAZUA Evation 1.0 Remote CD22, CL1414

### EQUIPMENT

€ 7.599,-

<b>FRAME</b>	NOX Helium Carbon frame	<b>SEAT POST</b>	FOX Transfer Factory Post
<b>FRAME SIZES</b>	M, L	<b>SADDLE</b>	PROLOGO Proxim W650
<b>FORK</b>	FOX 36 Factory RC2, 27,5"+, 180mm		Microfiber P1 +Grip
<b>REAR SHOCK</b>	FOX DHX2 230x60mm	<b>WHEELSET</b>	STAN'S Notubes Flow Team, 27.5"
<b>STEM</b>	RENTHAL Apex 35	<b>TYRES</b>	CONTINENTAL Der Baron Project 27.5x2.4"
<b>HANDLEBAR</b>	RENTHAL Fatbar 35		ProTaction Apex
<b>GRIPS</b>	ODI	<b>BRAKES</b>	MAGURA MT7 HC

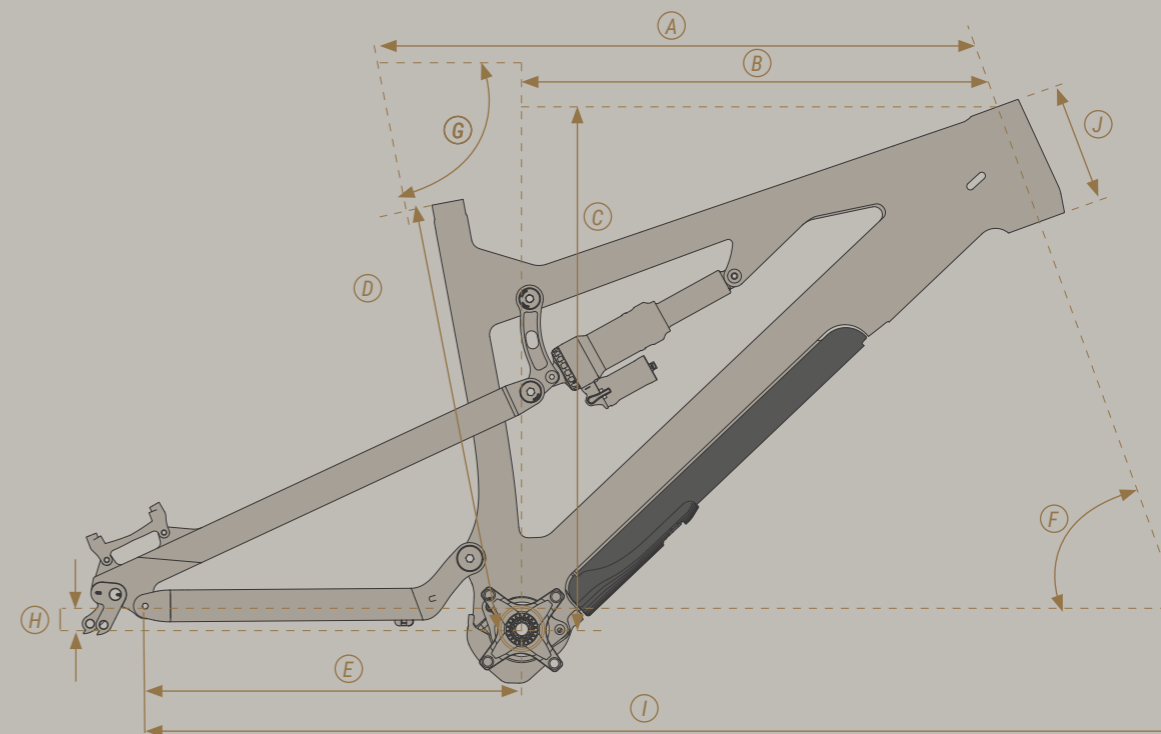

## 7.1 ENDURO EXPERT

### DRIVE

<b>CRANKSET</b>	SRAM EX1 E-Crank, 165mm, 34T
<b>REAR DERAILLEUR</b>	SRAM GX Eagle 12x
<b>SHIFTER</b>	SRAM GX Eagle 12x
<b>CASSETTE</b>	SRAM PG 1230, 11-50T
<b>MOTOR</b>	FAZUA drive pack
<b>BATTERY*</b>	FAZUA battery 7000 evation 1.0 36V-7Ah-252Wh
<b>CHARGER</b>	FAZUA charger
<b>DISPLAY</b>	FAZUA Evation 1.0 Remote CD22, CL1414

### EQUIPMENT

€ 5.999,-

<b>FRAME</b>	NOX Helium Carbon frame	<b>SEAT POST</b>	ROCKSHOX Reverb Stealth
<b>FRAME SIZES</b>	M, L	<b>SADDLE</b>	PROLOGO Proxim W450
<b>FORK</b>	ROCKSHOX Lyrik Select, 29"/27.5"+, 180mm	<b>WHEELSET**</b>	DT SWISS H1900 Spline, 27.5"
<b>REAR SHOCK</b>	ROCK SHOX Super Deluxe Coil Select R 230x60mm	<b>TYRES**</b>	CONTINENTAL Trail King 27.5x2.4" Shieldwall
<b>STEM</b>	NOX Components 35 Stem	<b>BRAKES</b>	MAGURA MT5 HC
<b>HANDLEBAR</b>	NOX Components 35 Risebar		
<b>GRIPS</b>	ODI		



		M		L	
		27.5"	29"	27,5"	29"
<b>A</b>	Top tube (horizontal)	609.8mm	609.8mm	635.3mm	635.3mm
<b>B</b>	Reach	445,3mm	445,3mm	469mm	469mm
<b>C</b>	Stack	614mm	614mm	618mm	618mm
<b>D</b>	Seat tube	435mm	435mm	478mm	478mm
<b>E</b>	Chain stay	453mm	468mm	453mm	468mm
<b>F</b>	Steering angle	65°	65°	65°	65°
<b>G</b>	Seat angle	74.5°	74.5°	74.5°	74.5°
<b>H</b>	BB drop	15mm	15mm	8mm	8mm
<b>I</b>	Wheelbase	1230mm	1244mm	1257mm	1272mm
<b>J</b>	Head tube	130mm	130mm	135mm	135mm

Equipment and prices subject to change

Battery Cover for extracted drive unit included

\* Additional battery FAZUA 7000 evation 252Wh: 299€ SRP  
Only valid in connection with bike purchase

\*\* Additional tyre/wheel sizes also available



**NOX  
CYC  
LES**

NOXCYCLES.COM



PERFECT E-BIKE.  
PERFECT DAY.

IMPRINT

Nox Cycles Austria Gmbh  
Rohrerstr. 51  
AT-6280 Zell am Ziller  
Riders: NOX employees, NOX E-Bike Squad and friends  
Photos: Simon Beizae  
Design: Fargo Cir. Studio

Version 2020.1

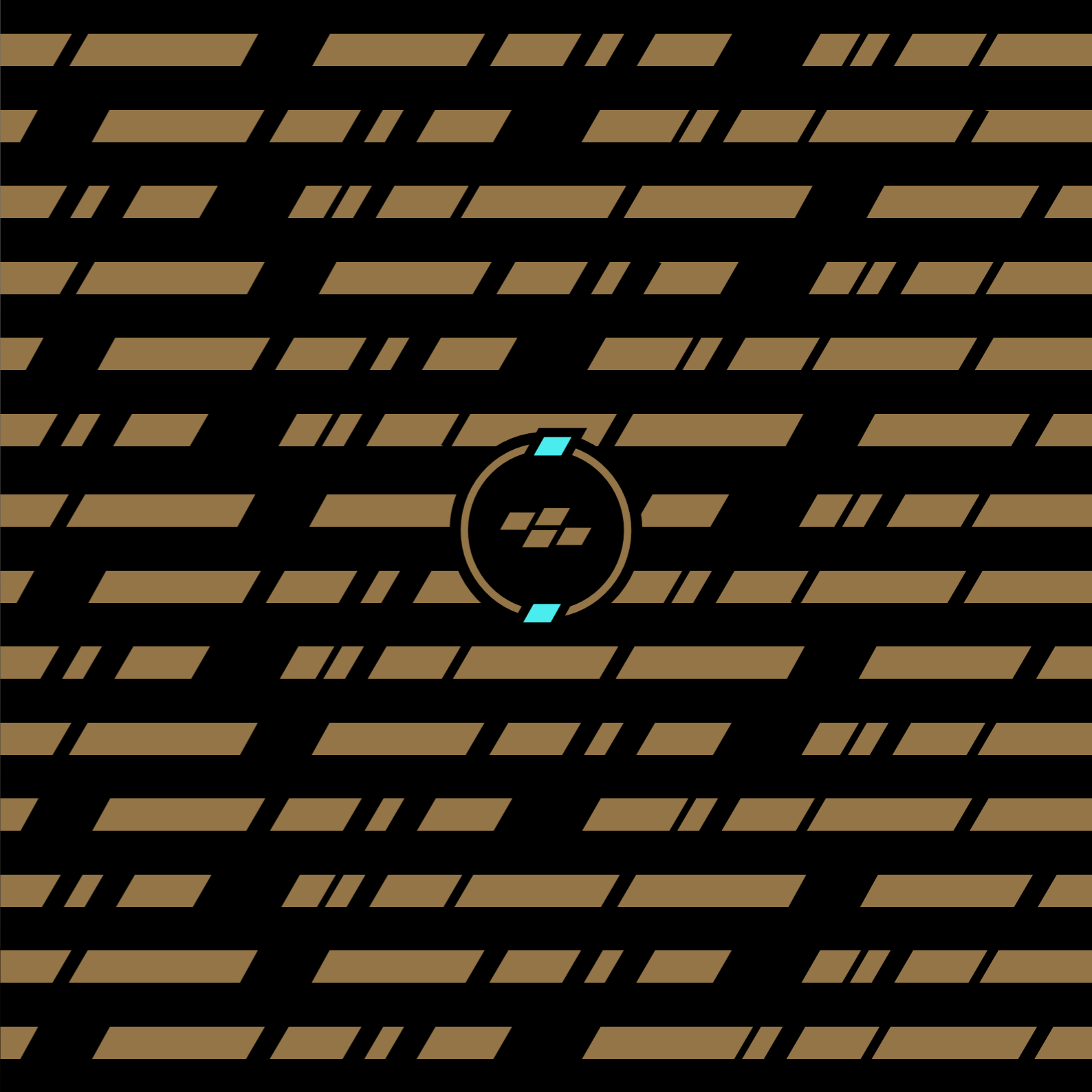



**AT** **Nox Cycles Austria GmbH**  
Rohrerstraße 51  
6280 Zell am Ziller  
Austria

+43 (0)5282 226 99

**DE** **Nox Cycles GmbH**  
Oranienburger Straße 1 - 3  
D-10178 Berlin-Mitte  
Germany

+49 (0)30 36 753 237

**CH** **Nox Cycles Switzerland GmbH**  
Grundstrasse 2  
6343 Rotkreuz  
Switzerland

+41 41 520 05 1 - 0



**NOXCYCLES.COM**

info@noxcycles.com